



CUMBRIA'S
MUSEUM OF
MILITARY LIFE



REMEMBRANCE 100 OPEN ART EXHIBITION

21 May – 2 Sept 2018
Information for Artists

What is 'Remembrance 100'?

2018 marks 100 years since the end of the First World War. This Heritage Lottery Funded exhibition will consist of 100 selected artworks which have been made as a creative response to the theme of 'Remembrance'. 2018 is the centenary of end of the First World War and the start of Remembrance as we know it today.

We want artists to look at the impact of Remembrance. This can be reflected in the question 'What does Remembrance mean to me?' What do you think of when you hear the word Remembrance? How does it make you feel? We want artists to creatively express their feelings.

The exhibition is an opportunity to not only remember the First World War but to explore how Remembrance has evolved over the last 100 years and is expressed today.

Who can enter?

Anyone whom is resident in the counties of Cumbria and Dumfries & Galloway whether a professional or non-professional artist.

How many works can I enter?

Each artist can enter 1 or 2 works. All 2D artforms are eligible for entry including painting, drawing, printmaking, textiles and photography. We cannot display 3D or AV/Digital artwork.

How much does it cost?

Entry is free.

How do I enter?

Entry is done through emailing the Curator a digital photograph/s of your artwork/s and a completed entry form. The entry window is between Monday 26th February and Monday 7th May 2018. Images should be at least 300dpi and approximately 1MB in size. See image sheet below for full details.

How will the work be selected?

26 Feb – 7 May 2018	Digital submission via email
8 - 9 May	Judging of digital submissions
10 May	Selected artists notified
14 May 10am – 6pm	Selected artworks to be delivered to Cumbria's Museum of Military Life
20 May, 3-5pm	Exhibition Launch Event – invitation only
21 May – 2 Sept 2018	Exhibition
4 & 5 Sept 10am-6pm	Collection of exhibited and unsold work from Cumbria's Museum of Military Life (please bring proof of identity)



Judging is done using digital photos of the artworks, which are submitted by the artist via email. The selected artworks will then be announced. Artists selected for the exhibition will need to deliver their framed artworks to Cumbria's Museum of Military Life. The judges will include the Remembrance 100 Curator Jamie Barnes, and two independent artist/curators.

The exhibition will take place inside Cumbria's Museum of Military Life in Carlisle Castle between 21st May and 2nd September 2018.

How do I present my image/s?

Please see the Image Information Sheet (below) for full details

How do I present my work?

If your work is selected you will need to bring your artwork/s to Cumbria's Museum of Military Life, in Carlisle Castle. Labels must clearly show your: Name, Title, Medium, Price, and Entry 1 or 2. Attach one label to the back of your entry, and one which is detachable. The back of all artworks must be fitted with d-rings about ¼ the way from the top of the frame (see diagram on right) to fit the Museum's gallery hanging system. The d-rings have to be fitted quite high up to stop the picture pitching forward on the hooks. The price should include the frame. All works on paper should be framed. Clip frames will not be accepted. If you have any queries please contact Remembrance 100 Curator Jamie Barnes via email on remembrance100@gmail.com or call 07747 633136. Works damaged on arrival or unsuitably framed will not be entered.

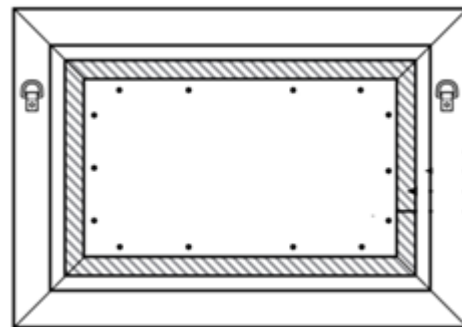

Is my work insured?

No, you need to arrange your own insurance.

How will I know if my work has been sold?

A red dot will be attached to the label on the wall. Payment will be required in full by the purchaser prior to the end of the exhibition. Purchasers can collect their art works from the Museum after the exhibition. The artist should contact Cumbria's Museum of Military Life to find out if a work has been sold prior to collection on 01228 532774 enquiries@cmoml.org

Does the gallery take commission if I sell my work?

Yes, a commission of 10% on the actual price realised during the exhibition will be payable to Cumbria's Museum of Military Life to help support its programme. The sale amount/s minus our commission will be sent to you by post after 2 September 2018.

What happens after the exhibition?

Work that has been exhibited and unsold can be collected from Cumbria's Museum of Military Life, Carlisle on either 4th or 5th September between 10am-6pm. If you need to make alternative arrangements for collection, contact the Museum on 01228 532774 enquiries@cmoml.org

Cumbria's Museum of Military Life accepts no responsibility for any unsold works after 30th September 2018 and any work that remains at the Museum after this date will be disposed of.

About Cumbria's Museum of Military Life

Cumbria's Museum of Military Life is Carlisle's newest visitor attraction, telling the 300-year story of Cumbria's County Infantry Regiment and its soldiers past and present. Cumbria's Museum of Military Life is run by the King's Own Royal Border Regiment Museum Trust, a Registered Charitable Trust No. 27143.

Cumbria's Museum of Military Life cannot accept responsibility for misunderstandings arising from artists' failure to read this information.



CUMBRIA'S
MUSEUM OF
MILITARY LIFE



REMEMBRANCE 100 OPEN ART EXHIBITION

Image information sheet

Submission guidelines

- Submit one high quality image for each artwork submitted (jpeg, minimum 300dpi approx 1MB in size)
- Jpegs must be submitted with a title so that we can easily identify them. This should be your surname, followed by your first name or initial, plus a number (1 or 2).
eg: **surname_first name1.jpg**
- Ensure images are saved in the correct orientation.
- Images should be cropped appropriately. The image should not include the frame or excessive amounts of background unless it is integral to the work or gives a sense of scale.
- Please provide dimensions of each piece of work and their titles.
- You should only submit images that you are happy to be used in promotional material and on our website.
- Remember that your photos do not only showcase a particular piece, but reflect you and your work.

Tips on how to produce good quality images

If your budget and timescale allows you may want to hire a professional photographer. Make sure you get recommendations from trusted contacts and see examples of the photographer's work before agreeing to anything.

If you prefer to take the photos yourself here are some hints and tips that should help you.

- Learn about the macro function on your digital camera you are using. This affects all sorts of things; including the sharpness of the image and how fuzzy your backgrounds are. Check the camera manual for details.
- A steady surface is always a better option than holding the camera by hand. If you do not have a tripod, try using another sturdy support such as a stack of books.
- Try turning off the flash or using fill-in flash. An on-camera flash tends to flatten your photo and can make images unappealing. It can also create a glare on your image. Don't take pictures at night and try to find a good source of daylight to avoid the flash where you can.
- Learn about white balance. This refers to how your camera reads the colour of light. If your photos are turning out with yellow or blue tinges, you have colour balance issues. Your camera manual should tell you how to solve this.
- Make sure you have plenty of images to choose from. The more shots you take the more likely it is that you will stumble across something that's perfect.
- If you do not have the software to edit and crop your images (or you don't like what you have) you could try <https://pixlr.com/> this is relatively simple to use and free to sign up.
- If you are not happy with your image then take some more. Photoshop (and other editing software) should be used to enhance your image rather than disguise problems. With a bit of experimentation your photos will look great. It is worth a little time to get it right